

Islamic Banking Fiqh: Urgency and Economic Challenges in the System of Islamic Financial Institutions (LKS) in Indonesia

Tentiyo Suharto

Mandailing Natal State Islamic College, Indonesia

Abstract

Islamic banking is a form of financial system based on sharia principles. The urgency of fiqh in Islamic banking is very important because it is a guideline in carrying out transactions in accordance with Islamic law. One of the important aspects in Islamic banking is the application of fiqh muamalah in the products of raising funds (funding), channeling funds (landing) and services (services) in the payment traffic offered. This research uses a qualitative method. Data were collected through literature review, analysis of bank policy documents related to products at Islamic financial institutions (LKS). The result of this study is that although the application of Islamic banking fiqh has been running well, especially in relation to murabahah, mudharabah, musyarakah, ijarah, kafalah, wakalah and hiwalah contracts, it has been applied in accordance with the principles of Islamic banking fiqh. However, there are still some challenges such as the public's not optimal understanding of the concept of Islamic banking, especially in LKS, regulations that continue to evolve, and competition with conventional banking or conventional financial institutions that still require increased education to the public as well as strengthening regulations to ensure compliance with sharia principles. To be able to contribute to the development of Islamic banking specifically in the field of LKS in Indonesia.

Keywords: Fiqh of Islamic Banking, Islamic Financial Institutions, Murabahah, Mudharabah, Musyarakah, Ijarah, Kafalah, Wakalah, Hiwalah.

1. Introduction

Islamic banking is a financial system that operates based on sharia principles, especially the law of fiqh muamalah. Although Islamic banking has developed rapidly, there are still some fiqh issues that are debated. In practice, Islamic banking is faced with various fiqh challenges that require in-depth study to remain in accordance with sharia principles and can be applied effectively in financial institutions, especially in Islamic financial institutions (LKS). Fiqh issues in Islamic banking are increasing day by day including (H.A. Abd. 2011):

Usury in Islamic banking products. Usury (interest or addition) is prohibited in Islam, but some Islamic banking products are considered to still have elements of hidden usury. For example, in murabahah contracts (sale and purchase with a profit margin), some Islamic banks charge a fixed profit like conventional interest, giving the impression of "interest in disguise." In fiqh muamalah, murabahah is allowed as long as there is no element of usury and the contract is in accordance with the principle of sale and purchase (al-ba'i). If the contract is only a formality and the practice is similar to a fixed interest system, then it is considered not in accordance with sharia principles.

Gharar (uncertainty) in contracts. Some contracts in Islamic banking contain elements of gharar (uncertainty), for example in *istishna'* (ordering goods) or *musyarakah mutanaqisah* (cooperation with gradually decreasing ownership) contracts. Customers often do not understand the contracts used, so there is a possibility of unfairness. Mild gharar (*gharar yasir*) is still tolerated in Islam, but excessive gharar can cause the contract to be void. Transparency in the contract is key so that customers understand their rights and obligations.

Maysir is a term in Islamic law that means gambling or transactions that contain elements of high speculation (*gharar*). In the context of Islamic economics and finance, maysir refers to activities that generate profits uncertainly, without comparable effort and have the potential to harm one party. Although Islamic banking is based on strict Islamic principles there are some challenges in ensuring that all products and services are free from maysir.

* Corresponding author.

E-mail address: tentyosuharto@stain-madina.ac.id

Here are some examples of how maysir can arise in Islamic banking: forex trading with excessive speculation. Some Islamic banks offer foreign currency trading services. However, if these transactions are carried out without real ownership of the currency or only based on price speculation, they may contain elements of maysir. Islamic banking must ensure that forex transactions are conducted in accordance with Islamic principles, such as bai' al-sarf contracts that require immediate handover and without excessive leverage, investments that contain elements of speculation. Islamic banks often invest in stocks or sukuk (Islamic bonds). However, if the investment is made without in-depth analysis or simply depends on price fluctuations without a clear basis, it can be considered speculative and contains maysir. Therefore, Islamic banks must apply fundamental analysis and ensure investment only in sharia-compliant companies, an obscure product of Islamic insurance (takaful). In the takaful system, participants pool funds together to help each other in emergencies. However, if takaful is managed with elements of high speculation such as promising large profits without clear calculations, it can lead to maysir. (Syauqoti, R., & Ghozali, M. 2018).

Therefore, participants' funds must be managed transparently and based on clear contracts such as tabarru' (grants) or wakalah bil ujah (representation in return for services), conventional bonds packaged as sukuk. Some Islamic banks issue sukuk that are ostensibly sharia-based but in practice are just a replication of conventional bonds without any real assets backing them. If profits are derived only from changes in market prices and not from the real income of the financed project, then elements of speculation and maysir may occur in derivative products in Islamic finance. Products such as options, futures or other derivatives in conventional form tend to be speculation-based. If Islamic banks try to offer derivative products without real ownership of the underlying assets or only for price speculation, then it violates sharia principles and contains elements of maysir. (Arifin, Fajar Zainal, 2009).

Tadlis in Islam is the act of concealing defects or giving a misleading description of a product or service in a transaction. Tadlis linguistically means “deception or opaque dealing” or “cheating” which is prohibited. In muamalah fiqh tadlis is divided into two main types: Tadlis al-'Ayb and Tadlis al-Sifah. Tadlis in the context of Islamic banking. In the Islamic banking industry tadlis can occur in various forms. Tadlis in the murabahah contract. Banks do not transparently disclose the cost of goods sold to customers. Information about the specifications of the goods financed is not in accordance with reality. Tadlis in a mudharabah contract. The bank or fund manager (mudharib) hides information about investment profits or losses from the customer (shahibul maal). Inaccurate financial statements to the detriment of the capital owner. Tadlis in ijarah contracts where the bank leases goods or assets without disclosing the actual condition, for example, a car or property that turns out to have hidden defects. Disclosure of additional costs that are not clear from the start. Tadlis in Islamic financing products. Islamic banks offer products that claim to be usury-free but in practice still apply mechanisms similar to conventional interest. Promise of fixed profits in investments that should be based on profit-loss sharing. (Andrianto, and Firmansyah Anang, 2019).

Differences of opinion in the standardization of contracts. The absence of uniform standards in Islamic banking contracts leads to differences in interpretation. Fatwas from the National Sharia Council (DSN) in Indonesia sometimes differ from fatwas from other countries, such as AAOIFI (Accounting and Auditing Organization for Islamic Financial Institutions). In Islamic fiqh, differences of opinion are normal due to the existence of various schools of fiqh. However, harmonization is necessary so that Islamic banking regulations remain consistent at the global level. Use of funds in non-halal investments. There are concerns that funds raised by Islamic banks are used for investment in sectors that are not in accordance with sharia, such as the alcohol industry, gambling, or sectors that contain elements of high speculation. Not all Islamic banks have a transparent mechanism in managing customer funds. Islamic sharia compliance requires that investments must be in accordance with halal principles and must not contain haram elements. Therefore, it is important for Islamic banks to have a strict sharia supervision mechanism. Hybrid agreements and their relation to sharia. (Hirsanuddin, 2008).

Some Islamic banking products use hybrid contracts, which is a combination of several contracts in one transaction, such as a murabahah contract combined with an ijarah (rental) contract. There is a debate whether the combination of these contracts is still in accordance with sharia principles or not. In fiqh principles, combining contracts is allowed as long as there is no contradiction or injustice in one of the contracts. However, if the combination of contracts causes gharar or exploitation of one of the parties, then the contract becomes invalid.

2. Literature Review

2.1 Fiqh

Fiqh comes from the Arabic word al-fiqh, which means “deep understanding”. In terms of terms, fiqh is defined as the science that discusses the laws of sharia derived from detailed arguments. This definition shows that fiqh is a science

that regulates all aspects of Muslim life. In the context of national law, fiqh is termed regulation, namely laws that are recognized in Indonesia which are sourced from (Pancasila, the 1945 Constitution, Legislation, Customs and customs, Treaties or International Agreements, Jurisprudence or Court Decisions, Opinions of Famous Jurists or Doctrines). (Muhammad Adnan, 2024).

In Islamic terminology, fiqh is defined as the study of Sharia laws relating to human actions based on detailed arguments. The source of law in fiqh relies on several main sources of (the Qur'an, hadith, ijma' or agreement of scholars, qiyas or determination of law based on analogy to cases that have similar legal illat, ijihad or the efforts of scholars in exploring Islamic law that is not explicitly mentioned in the main source. The development of fiqh in Islamic history is divided into several periods, namely the time of the prophet Muhammad Saw: Islamic laws were directly determined based on the revelations received by the Prophet, the khulafaur rasyidin period: the development of fiqh while adhering to the Qur'an and Hadith and the ijihad of the companions, the period of the imam mazhab: The emergence of major fiqh schools such as Hanafi, Maliki, Shafi'i, and Hanbali, the period of codification of fiqh: the compilation of fiqh books to standardize Islamic laws, the modern period: the development of fiqh that adapts to the needs of the times through contemporary ijihad. The development of fiqh underwent several phases from the time of the prophet Muhammad to the modern era, which shows that Islamic law is dynamic and relevant throughout the ages.

2.2 Islamic Banking

Islamic banking is a banking system that operates based on Islamic sharia principles that prohibit usury, gharar maysir and Tadlis. Islamic banks offer products and services that comply with sharia principles such as murabahah, mudharabah, musyarakah, ijarah, kafalah, wakalah and hiwalah. The principles of Islamic banking are the principle of justice where profits/risks are shared fairly between banks and customers, the principle of partnership where the relationship between banks and customers is cooperation or partnership, not lending/financing, the principle of prohibition of usury where Islamic banks do not charge interest payments on financial transactions, the principle of transparency where all contracts in Islamic banking must be clear and not contain elements of fraud, the principle of halalness or the products and services offered must comply with Islamic law. Islamic banking products operate with a different mechanism from conventional banking where all transactions must meet sharia principles and are supervised by the Sharia Supervisory Board (DPS) with categories (A.G Anshori, 2018).

Islamic banking regulations in Indonesia are governed by various regulations including: Law Number 21 of 2008 concerning Islamic Banking. Regulates the operations and principles of Islamic banking in Indonesia, Fatwa of the National Sharia Council (DSN-MUI) provides guidelines for Islamic banking products in accordance with Islamic law, Financial Services Authority (OJK) regulations oversee and regulate policies related to the Islamic banking industry and Bank Indonesia (BI) as a monetary regulator that supports the development of Islamic banking. Regulations are constantly evolving and demand rapid adaptation from the industry. Islamic banking is a unique financial system based on Islamic law, has different products from conventional banks, and offers its own benefits and challenges in its development. (Amir M.F, 2020).

2.3 Sharia Financial Institution (LKS)

Understanding Sharia Financial Institutions (LKS) has an important role in the economic system, especially in countries with a majority Muslim population. LKS operates based on sharia principles that avoid elements of usury, gharar, maysir and tadlis. With the development of the Islamic finance industry, many countries have begun to adopt this system to provide a fairer financial alternative in accordance with Islamic principles. LKS is an institution engaged in the financial sector. LKS provides various financial services such as banking, insurance, financing, and investment in accordance with Islamic law. The legal basis for LKS operates based on Islamic law contained in the Qur'an, hadith, and fatwas from the National Sharia Council (DSN-MUI). (Khidmatul, et al. 2023).

Types of LKS consist of several types including: Sharia Banks, Baitul Maal wat Tamwil (BMT), Microfinance Institutions (Islamic Finance), Sharia Insurance, Sharia Capital Markets, Sharia Pawnshops, Zakat, Infaq and Waqf Institutions (ZISWAF), Sharia Microfinance Institutions. Akad LKS uses various contracts in carrying out its operations, among others: Murabaha, Mudharabah, Musyarakah, Ijarah, Kafalah, Hiwalah and Wakalah. The role of LKS in the economy has a strategic role in increasing sharia-based financial inclusion. This important role in the economy by providing financial services in accordance with Islamic principles.

3. Research Method and Materials

The method in writing this scientific work the author uses the library research method. Library research is research conducted using literature (literature), both in the form of books, notes, scientific journals, articles, seminar results, symposium results, conferences and reports on previous research results. This type of research uses a qualitative method with a descriptive-analytical approach. The data sources used are primary data directly related to the topic of Islamic banking fiqh and Islamic bank document studies. Secondary data are literature, journals, and DSN-MUI fatwas and regulations related to the object of research.

4. Results and Discussion

4.1 Basic Concepts of Fiqh

Fiqh perbankan syariah merupakan cabang ilmu dalam Islam yang berkaitan dengan hukum-hukum syariat dalam kehidupan sehari-hari. Ilmu fiqh sangat penting bagi umat Islam sebagai pedoman dalam beribadah, bermuamalah, dan menjalankan kehidupan sesuai dengan ketentuan perintah Tuhan. Pemahaman terhadap fiqh memerlukan landasan teori yang kuat agar tidak terjadi kesalahan dalam pengamalan ajaran Islam. (Hasballah Thaib. 2005).

Fiqh perbankan syariah adalah cabang ilmu fiqh yang membahas aturan dan hukum Islam yang berkaitan dengan transaksi keuangan dalam perbankan syariah baik berupa manajemen, akuntansi, pelaporan, produk, akad, sumber daya manusia, etika bisnis, pelemagaan, organisasi, pengawasan, auditing, perpajakan dan sanksi/pelanggaran dalam perbankan. Oleh karena itu, Fiqh perbankan syariah memiliki peran yang signifikan dalam memastikan transaksi keuangan tetap sesuai dengan prinsip Islam.

4.2 The Urgency of Islamic Banking Fiqh

The urgency of fiqh in Islamic banking is crucial because it serves as a guide in carrying out financial transactions in accordance with Islamic principles. The urgency of fiqh in Islamic banking can be explained through several aspects: sharia compliance, which ensures that all banking products and services are in accordance with Islamic law, public trust, which provides assurance to customers that the funds they save and use in transactions remain in the sharia corridor, economic stability, which is with the principle of risk sharing, Islamic banking can create a more stable financial system, ensuring sharia compliance, the urgency of fiqh in Islamic banking lies in its role to ensure that every financial product offered remains in accordance with Islamic law. (Budiman, A., Gamaginta, & Aziz, A. 2018).

This is important to maintain customer trust as well as the legality of Islamic bank operations, increase public trust, namely the strict application of fiqh in Islamic banking makes Muslim communities more confident in using Islamic financial services than conventional ones, provide equitable financial alternatives, namely Islamic banking fiqh plays a role in creating a fairer financial system, especially in reducing economic inequality and providing opportunities for all parties to participate in the Islamic financial system.

4.3 Application of Fiqh in Islamic Financial Institutions (LKS)

4.3.1 Murabahah (al-bai')

Murabahah (al-bai') is a sale and purchase contract in which the seller states the acquisition price of the goods and adds a profit margin agreed upon with the buyer. This agreement is included in the category of amanah sale and purchase because the principal price and profit must be known by both parties. Murabaha (sale and purchase) is divided into 2 (two), namely salam sale and istishna' sale and purchase. Salam sale is a transaction in which the buyer pays the full price of the goods in advance, while the seller promises to deliver the goods at an agreed time in the future. Istishna' sale and purchase is an order contract for goods that must be produced or made in advance according to specifications agreed between the buyer and seller. The legal basis for murabaha contracts in the Al-Qur'an, Hadith, Ijma' Ulama (Fatwa DSN-MUI) and Sharia Banking Law Number 21 of 2008 concerning Sharia Banking as well as national laws applicable in Indonesia. (Sukmadewi Y.D, 2016).

The application of the murabaha contract in murabaha is often applied in financing, for example: vehicle financing: the bank buys a vehicle and then sells it to the customer with an additional profit margin. Home financing: banks or LKS buy houses first, then sell them to customers with a fixed installment system. Purchase of capital goods: banks or LKS provide goods for business purposes with murabahah mechanism. (Zulhamdi, 2022).

Examples of murabahah contract products in Islamic banking/LKS:

- a) Vehicle Financing: A customer wants to buy a car worth Rp 300,000,000. The bank buys the car from the dealer at Rp 300,000,000. The bank resells the car to the customer for Rp 330,000,000 (with a profit margin of Rp 30,000,000). The customer pays in installments for 5 years. If there is a delay in payment, the bank can impose administrative penalties that are not usury.
- b) Home Financing (KPR Syariah): A customer wants to buy a house worth Rp. 500,000,000. The bank buys the house from the developer for Rp. 500,000,000. The bank sells the house to the customer for Rp. 600,000,000 (profit margin of Rp. 100,000,000). The customer pays with a fixed installment scheme for 15 years. No interest, and fixed installments without interest rate fluctuations.
- c) Business Capital Financing: A businessman needs capital to buy a production machine worth Rp. 200,000,000,-. The bank buys the machine from a supplier at a price of Rp. 200,000,000,-. The bank sells the machine to the entrepreneur at a price of Rp. 230,000,000. The entrepreneur pays in installments within 2 years. (with a profit margin of Rp. 30,000,000). The entrepreneur or customer pays in installments for 5 years. If there is a delay in payment, the bank can impose administrative penalties that are not usury.

An illustration of the murabaha contract cycle can be seen in the following figure:

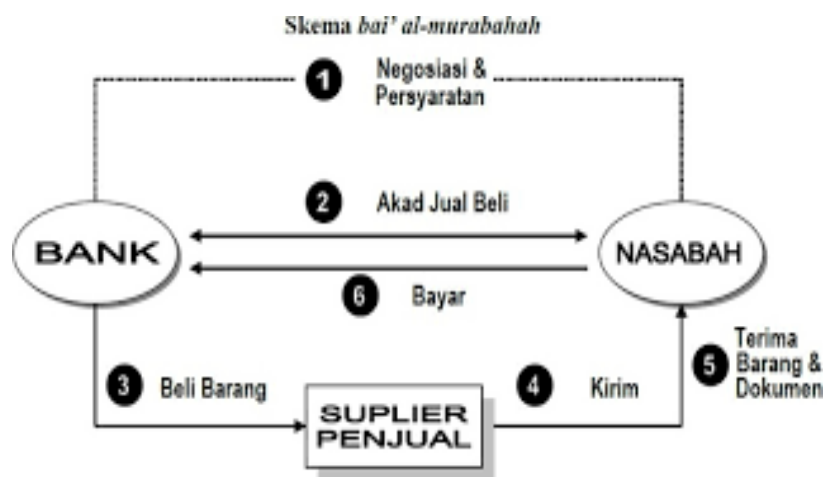

Figure 1. Murabaha Contract Design (in Indonesia)

4.3.2 Mudharabah (Partnership agreement between financiers and business managers).

The definition of mudharabah contract is a cooperation contract between the owner of capital (shahibul maal) and the business manager (mudharib) in which profits are shared based on agreement, while losses are borne by the owner of the capital unless there is negligence or violation on the part of the business manager (A, Baraba, 1999).

Types of mudharabah contracts. Mudharabah is divided into two types: mudharabah muthlaqah. There are no specific restrictions on the use of capital. The business manager has discretion in developing the business. Mudharabah muqayyadah: the owner of the capital imposes restrictions on the type of business or the way of management. The application of mudharabah in LKS is widely applied in the banking and Islamic finance industry. Challenges and Solutions in the application of mudharabah. Challenges: business managers may not be transparent about the profits earned, moral risk/business managers may act untrustworthy, lack of public understanding/many business actors still do not understand the concept of mudharabah. Solution: increase transparency with periodic audits and financial reports, implement a stricter supervision and regulation system, increase education about Islamic economics to the public. (M. Kholid, 2018).

Types of mudharabah in Islamic banking. Mudharabah muthlaqah There are no specific restrictions from the owner of the capital on how the funds are managed by the manager. Example: Mudharabah Savings, Mudharabah Deposits. Mudharabah Muqayyadah. The owner of the capital provides certain restrictions on the use of funds, such as certain sectors or types of businesses. Example: Mudharabah-based working capital financing: mudharabah contract products in Islamic banking:

- a) Mudharabah savings. Concept: The customer (shahibul maal) deposits funds with the bank. The bank (mudharib) manages the funds in a halal and productive business. Profits are shared according to the agreed ratio.
- b) iB Mudharabah Savings, Hajj Savings with mudharabah contract Advantage: Customers get more competitive profit sharing compared to conventional bank interest. Bank has the freedom to manage funds productively. Risks: If the bank experiences losses in management, customers may lose profits (but not lose principal except under certain conditions).
- c) Mudharabah deposit concept: Customers deposit funds with the bank within a certain period of time (1, 3, 6, or 12 months). The bank manages the funds for Islamic investment. Profits are shared according to the agreed ratio e.g. 60:40, 70:30 etc. Products: iB Mudharabah time deposits, Islamic profit time deposits: Profit sharing ratio is usually higher than mudharabah savings. Can be automatically renewed with the same contract. Risk: if the bank does not make a profit, the customer only gets back the capital without profit. Financing Business Capital with Mudharabah Agreement Concept: The bank provides funds to the entrepreneur (mudharib) to manage in business. Profits are shared based on the agreed ratio. If there is a loss not due to the negligence of the entrepreneur, the loss is borne by the bank as the owner of the capital.

An illustration of the mudharabah contract cycle can be seen in the figure: below:

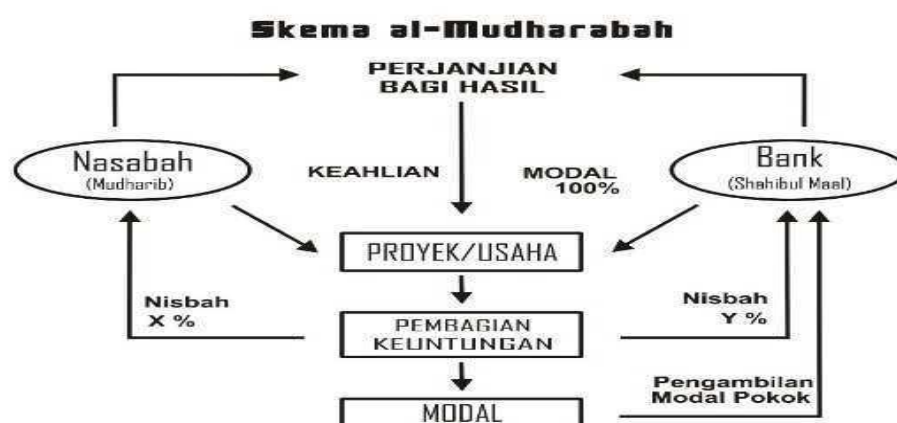

Figure 2. Mudharabah Contract Design (in Indonesia)

Musarakah comes from the word “syirkah” which means partnership or cooperation. In fiqh terminology, musarakah is defined as a cooperation contract between two or more parties in capital where profits are shared based on agreement, while losses are borne in accordance with the portion of capital included. The application of musarakah contracts in LKS includes: business financing: Islamic banks provide capital to customers to run businesses and share profits according to the portion of capital. Property purchase: the musarakah mutanaqishah contract is used in gradual home ownership. (Muhammad Syafii Antonio. 2001).

In Investment and Business. Islamic Venture Capital: Investors and entrepreneurs work together on a project with profit sharing. Partnership in trade: two parties work together in a trading business with a profit-sharing system. Challenges and Solutions in Implementing the Musarakah Agreement. Challenges of imbalance in capital management. Risk of moral hazard (management that is not trustworthy). Lack of public understanding of sharia contracts. Solution. Increased regulation and transparency in the implementation of the contract. Strengthening sharia supervision by the Sharia Supervisory Board (DPS). Educating the public about musarakah contracts and their benefits.

The musarakah agreement is one of the important concepts in fiqh muamalah that allows sharia-based business cooperation with a fair profit-sharing system. The implementation of this contract has grown widely in Islamic banking and other business sectors. However, challenges in its implementation need to be overcome with better regulations and education to the public so that this contract can run according to sharia principles. Cooperation between two or more parties in a business. An illustration of the musarakah contract cycle can be seen in the following figure:

Skema Musyarakah



Figure 3. Musyarakah Contract Design (in Indonesia)

4.3.3 Ijarah A leasing system that is in accordance with Islamic law.

Ijarah agreement linguistically means “wage” or “rent”. In fiqh terms, an ijarah contract is a lease or wage agreement for the benefits of an item or service within a certain period of time for an agreed fee. Application of ijarah contracts in modern life. Property leases (houses, apartments, land) lease contracts are made with clear terms and time periods. The tenant must pay according to the agreement and must not damage the goods. Employment services (labor, transportation, consultants). Employees get paid for their services based on a work agreement. Online motorcycle taxi drivers work with the ijarah system. sharia leasing (IMBT). The following are some examples of Islamic banking / LKS products that use the Ijarah contract:

- a) Ijarah vehicle financing (IMBT). Mechanism: the customer chooses the vehicle they want to use. The Islamic bank purchases the vehicle and leases it to the customer for a certain period of time. After the lease period is over, the bank can transfer the ownership of the vehicle to the customer with a grant or sale and purchase mechanism. Advantage: the customer does not need to pay the price of the vehicle at once. More flexible installments compared to conventional financing schemes.
- b) Property financing (IMBT). Mechanism: The bank buys the property that the customer wants. The property is leased to the customer for a certain period with monthly payments. At the end of the period, ownership can be transferred to the customer. Advantages: an alternative for customers who do not want to buy property directly. Shariah compliant as it is free from usury.
- c) Medical Equipment or Heavy Equipment Financing. Mechanism: Islamic banks purchase medical equipment (e.g. MRI machines) or heavy equipment (e.g. excavators). The bank leases the equipment to a hospital or company. After the lease period ends, the ownership can be transferred to the customer. Benefits: Helps companies obtain production equipment without having to buy in cash.
- d) Education services (Ijarah for Services) Mechanism: The bank finances the cost of a person's education, then the student or guardian pays in installments over a certain period. Benefits: helping access to education with lighter payments. (Lukmanul Hakim, 2021).

This product is suitable for individuals and businesses who want to use goods or services without having to pay the full price upfront, while ensuring their transactions remain in accordance with sharia principles. Ijarah is a flexible contract that can be applied in various aspects of life, both in transactions of goods and services. Its application in modern economic contexts, such as property leasing, wage labor, and Islamic leasing, shows that ijarah remains relevant and in accordance with the principles of justice in Islam. Therefore, a good understanding of the pillars, conditions, and application of ijarah contracts is essential to avoid disputes and ensure halal and blessed transactions. An illustration of the ijarah contract cycle can be seen in the following figure:

SKEMA IJARAH

Aplikasi Teknis Pembiayaan Perbankan



Figure 4. Ijarah Contract Design (in Indonesia)

4.3.4 Kafalah

Kafalah is a guarantee contract in Islamic law in which a person (called kafil) is responsible for guaranteeing the fulfillment of an obligation by another party if that party fails to fulfill its obligations. This concept emphasizes the principles of mutual aid and solidarity, which are in line with Islamic teachings. Principles and mechanisms of kafalah. (Suryani, 2012). Example of kafalah application. Islamic banking/LKS:

- A customer applying for a loan may require collateral from a third party. If the customer fails to repay the loan, the kafil will be liable. Lease: in a lease contract, if the tenant is unable to pay the rent, a guarantor (kafil) may be engaged to ensure timely payment of the rent. Business Transactions: In labor contracts or delivery of goods, a guarantor can ensure that contractual obligations are properly fulfilled. Kafalah is an important instrument in various financial transactions and contracts in the Islamic world, providing a layer of protection and assurance for all parties involved. An illustration of the kafalah contract cycle can be seen in the following figure:

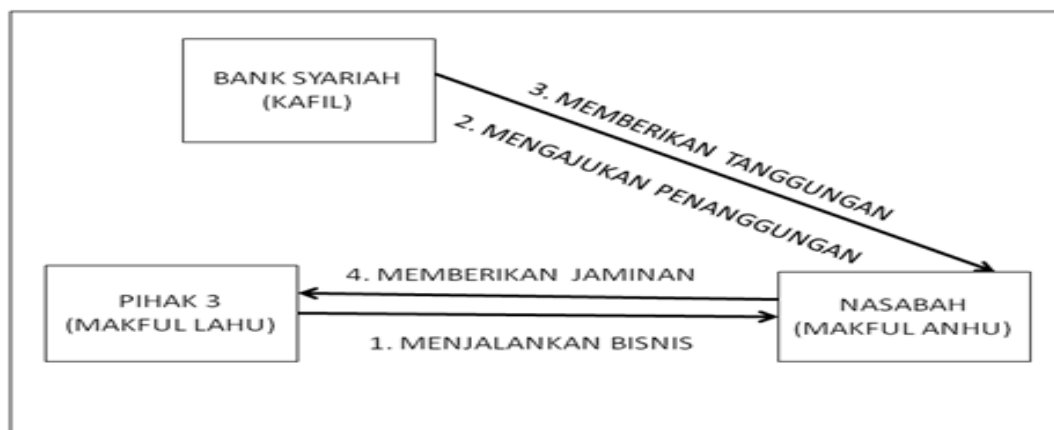

Figure 5. Kafalah Design Contract (in Indonesia)

4.3.5 Wakalah

Wakalah is a representative contract in which a person (muwakkil) authorizes another person (deputy) to perform an action or business on his behalf within the limits set by the Shari'ah. In the context of fiqh, wakalah can be applied in various aspects of life, whether in business transactions, finance, law, or worship. Types of wakalah. Wakalah

mutlaqah: representation without certain restrictions on action. Wakalah muqayyadah: Representation with certain restrictions. Wakalah bi al-ujrah: Representation for a fee or wage. Wakalah bi ghairi ujah: Representation without remuneration (voluntary). Application of the wakalah contract in modern life. Islamic Banking/LKS. Wakalah in banking transactions, such as wakalah bil ujah in Islamic credit card products and L/C (Letter of Credit) in international trade. Wakalah in Islamic insurance (Takaful), where the company acts as a representative to manage participants' funds. Buying and selling and trading. Represented real estate agent to sell or buy a house. Representation in the auction of goods. Law and administration. Lawyers who are authorized by clients in legal cases. Representation in marriage contracts (Mardani, 2010).

Investment and finance wakalah in Islamic mutual fund investment. Wakalah in Islamic capital market transactions. The validity and cancellation of the wakalah contract. The validity of a wakalah contract is valid if it fulfills its pillars and conditions. There must be no element of gharar or usury in the object being represented. Cancellation of wakalah. The contract ends with: completion of the assigned task. Death of one of the parties. Withdrawal of power by the muwakkil.

Wakalah contracts play an important role in various aspects of life, especially in financial, legal, and business transactions. With the right understanding, this contract can help in managing affairs more efficiently and in accordance with sharia principles. An illustration of the wakalah contract cycle can be seen in the following figure:

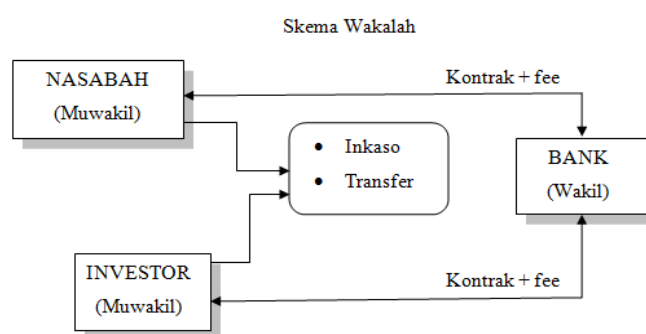

Figure 6. Wakalah Design Contract (in Indonesia)

4.3.6 Hawalah

The hawalah agreement is the transfer of debt from one party to another party who is obliged to pay it. In the context of Islamic economics, this contract is a solution for parties who have debts but want to transfer their payment obligations to other parties who are able or interested in paying off the debt. Hawalah comes from the word “hal”, which means to transfer. In muamalah fiqh, the hawalah contract allows a debtor (muhal) to transfer his debt obligations to another party (muhal 'alaih), with the consent of the creditor (muhal). (Ikhsanti, Nurul, et al, 2022).

Types of hawalah. Hawalah muthlaqah (Absolute). The transfer of debt is done without additional conditions, and the muhal 'alaih is obliged to pay off the debt. Example: A owes B Rp.10,000,000,-. A asks C to pay the debt, and B agrees. Hawalah muqayyadah (conditional). The transfer of debt is made with certain conditions, for example, it can only be paid after a certain date. Example: A owes B, but will only be paid by C after C receives payment from another party. Hawalah bi al-'Iwadh (Reciprocal). The transfer of debt is done in exchange for a certain reward, similar to the financing system in Islamic banking. As an illustration, here is an example of a hawalah contract:

- A transfers debt to C in exchange for a certain discount. Ali owes Budi Rp.5,000,000. However, Ali has a receivable of Rp.5,000,000 to Candra. To make it easier, Ali transfers his debt payment to Candra. Budi agrees to accept payment from Candra. This is a valid hawalah contract.
- Hawalah agreement in Islamic banking/LKS: A businessman has a debt to an Islamic bank of Rp.000.000,-, but he also has receivables from his clients in the same amount. With a hawalah contract, the businessman can transfer his payment obligations to his client, and the bank receives payment directly from the client.

The benefits of a hawalah contract: facilitate debt settlement with a transfer mechanism, increase the efficiency of financial transactions, prevent debt accumulation and facilitate repayment through a third party. The hawalah contract

is one of the solutions in Islamic economics to settle debts efficiently. By fulfilling the pillars and conditions, this contract can help parties who owe and have receivables to better manage their financial obligations. An illustration of the hawalah contract cycle can be seen in the following figure:

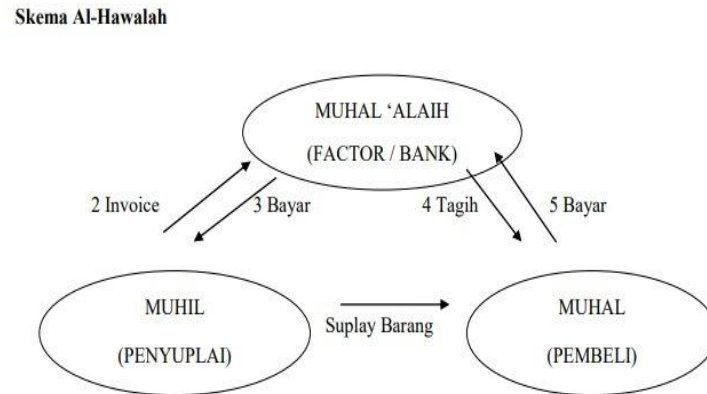

Figure 7. Hawalah Design Contract (in Indonesia)

4.4 Challenges and Solutions in the Implementation of Islamic Banking

Although Islamic banking continues to grow, there are several challenges faced, including: Lack of Public Understanding: Many people still do not fully understand the concept of Islamic banking. Complex Regulations: Differences in regulations between countries can be an obstacle in the implementation of Islamic banking. Competition with Conventional Banking: Islamic banking needs to offer more competitive products in order to compete. (Muhammad. 2000).

Islamic banking is a form of financial system based on sharia principles. The urgency of fiqh in Islamic banking is very important because it is a guideline in carrying out transactions in accordance with Islamic law. One of the important aspects in Islamic banking is the application of fiqh muamalah in the products of raising funds, channeling funds and services in the payment traffic offered, which is in accordance with the main task of operating an Islamic commercial bank (BUS). Solutions that can be applied include: Education and Socialization: Increase public understanding of the benefits and principles of Islamic banking. Strengthening Regulations: The government and financial institutions must ensure regulations that support the development of Islamic banking. Product Innovation: Develop more varied financial products to meet customer needs.

5. Conclusion

Islamic banking fiqh has a high urgency in the Islamic financial system. Its implementation in financial institutions not only ensures sharia compliance but also contributes to creating a fairer and more stable financial system. Although there are challenges in its implementation, with the right approach, Islamic banking can continue to grow and become a competitive alternative in the banking world. One of the important aspects in Islamic banking is the application of fiqh muamalah in the products of raising funds, channeling funds and services in the payment traffic offered in accordance with the main operational tasks of Islamic commercial banks (BUS). Islamic banking fiqh has a high urgency in ensuring that banking products and services are in accordance with Islamic principles including murabaha, mudharabah, musyarakah, ijarah, kafalah, hawalah and hiwalah. The application of fiqh in Islamic financial institutions includes various contracts that must comply with Islamic law. Although there are challenges in implementation, Islamic banking remains a financial alternative that is fair and in accordance with Islamic law.

References

Grady, J. S., Her, M., Moreno, G., Perez, C., & Yelinek, J. (2019). Emotions in storybooks: A comparison of storybooks that represent ethnic and racial groups in the United States. *Psychology of Popular Media Culture*, 8(3), 207–217. <https://doi.org/10.1037/ppm0000185>

- Adnan, M., et al. (2024). Membangun model ekonomi Islam yang berkelanjutan: Tantangan dan perspektif dari fiqh dan ushul fiqh. *El-Arbah: Jurnal Ekonomi, Bisnis dan Perbankan Syariah*, 8(1).
- Amir, M. F. (2020). Peran dan fungsi Otoritas Jasa Keuangan (OJK) dalam sistem keuangan di Indonesia (perspektif hukum Islam). *Al-Amwal: Journal of Islamic Economic Law*, 5(1).
- Andrianto, & Firmansyah, A. (2019). *Manajemen bank syariah*. Surabaya: Qiara Media.
- Anshori, A. G. (2018). *Perbankan syariah di Indonesia*. Yogyakarta: Gadjah Mada University Press.
- Arifin, F. Z. (2009). *Dasar-dasar manajemen bank syariah*. Tangerang: Aztera Publisher.
- Al-Zuhaili. (2006). *Al-fiqh al-islâmi wa adillatuhu*. Jakarta: Gema Insani.
- Ascarya. (2010). *Akad dan produk bank syariah*. Jakarta: PT Raja Grafindo Persada.
- Baraba, A. (1999). Prinsip dasar operasional perbankan syariah. *Bulletin of Monetary Economics and Banking*, 2(3).
- Budiman, A., Gamaginta, & Aziz, A. (2018). *Cetak biru penjaminan syariah: Implementasi fatwa nomor 118/DSN-MUI/2018 tentang penjaminan syariah*. Lembaga Penjamin Simpanan.
- Hakim, L. (2021). *Manajemen perbankan syariah*. Pamekasan: Duta Media Publishing.
- H.A, A. (2011). *Fiqh perbankan syariah: Transformasi fiqh muamalah ke dalam peraturan perundang-undangan*. Bandung: Refika Aditama.
- Hasballah, T. (2005). *Hukum aqad (kontrak) dalam fiqh Islam dan praktek di bank sistem syariah*. Medan: Program Pascasarjana Universitas Sumatra Utara.
- Hirsanuddin. (2008). *Hukum perbankan syariah di Indonesia*. Yogyakarta.
- Ikhsanti, N., et al. (2022). *Bank dan lembaga keuangan*. Padang, Sumatera Barat: Get Press.
- Khidmatul, et al. (2023). Implementasi konversi akad murabahah menjadi akad musyarakah mutanaqishah pada pembiayaan umum di Kospin Jasa Syariah Tegal. *Istishodiyah: Jurnal Ekonomi dan Perbankan Syariah*, 5(2).
- Kholid, M. (2018). Prinsip-prinsip hukum ekonomi syariah dalam Undang-Undang tentang perbankan syariah. *Asy-Syari'ah*, 20(2).
- Lewis, M. K., & Algaoud, L. M. (2003). *Perbankan syariah: Prinsip, praktik, dan prospek*. Jakarta: Serambi Ilmu Semesta.
- Mardani. (2010). *Hukum acara perdata peradilan agama dan Mahkamah Syariah*. Jakarta: Sinar Grafika.
- Muhammad. (2000). *Sistem dan prosedur operasional bank syariah*. Yogyakarta: UII Press.
- Antonio, M. S. (2001). *Islamic banking: Bank syariah dari teori ke praktik*. Jakarta: Gema Insani.
- Nurwahid. (2021). *Perbankan syariah*. Jakarta: Kencana.
- Pasaribu, F. (2022). Faktor-faktor yang mempengaruhi nasabah memilih bank syariah di Medan. *Jurnal Salman: Sosial dan Manajemen*, 3(2).
- Syafe'i, R. (2006). *Fiqh muamalah*. Bandung: Pustaka Setia.
- Anwar, S. (2007). *Hukum perjanjian syariah*. Jakarta: PT Raja Grafindo Persada.
- Syauqoti, R., & Ghozali, M. (2018). Analisis sistem lembaga keuangan syariah dan lembaga keuangan konvensional. *Iqtishoduna*, 14(1).
- Sukmadewi, Y. D. (2016). Peran Otoritas Jasa Keuangan (OJK) dalam pengawasan sektor bank umum syariah di Indonesia. *Jurnal Ilmiah Solusi Fakultas Ekonomi Universitas Semarang*, 15(3).
- Suryani, S. (2012). Sistem perbankan Islam di Indonesia: Sejarah dan prospek pengembangan. *Muqtasid: Jurnal Ekonomi dan Perbankan Syariah*, 3(1).
- Zulhamdi. (2022). Jual beli salam: Suatu kajian praktek jual beli online Shopee. *Jurnal Syarah*, 11(1).